

EINZELTEIL-LISTEN

SPARE-PARTS-LISTS

Für das Regnerprogramm

For sprinklers

ZX

ZA

PR

ZS

ZB

ZE

ZK

ZM

ZN

P2S

P2M

TV 2000

DREIFUSS/TRIPOD

ZX 30-3 WR

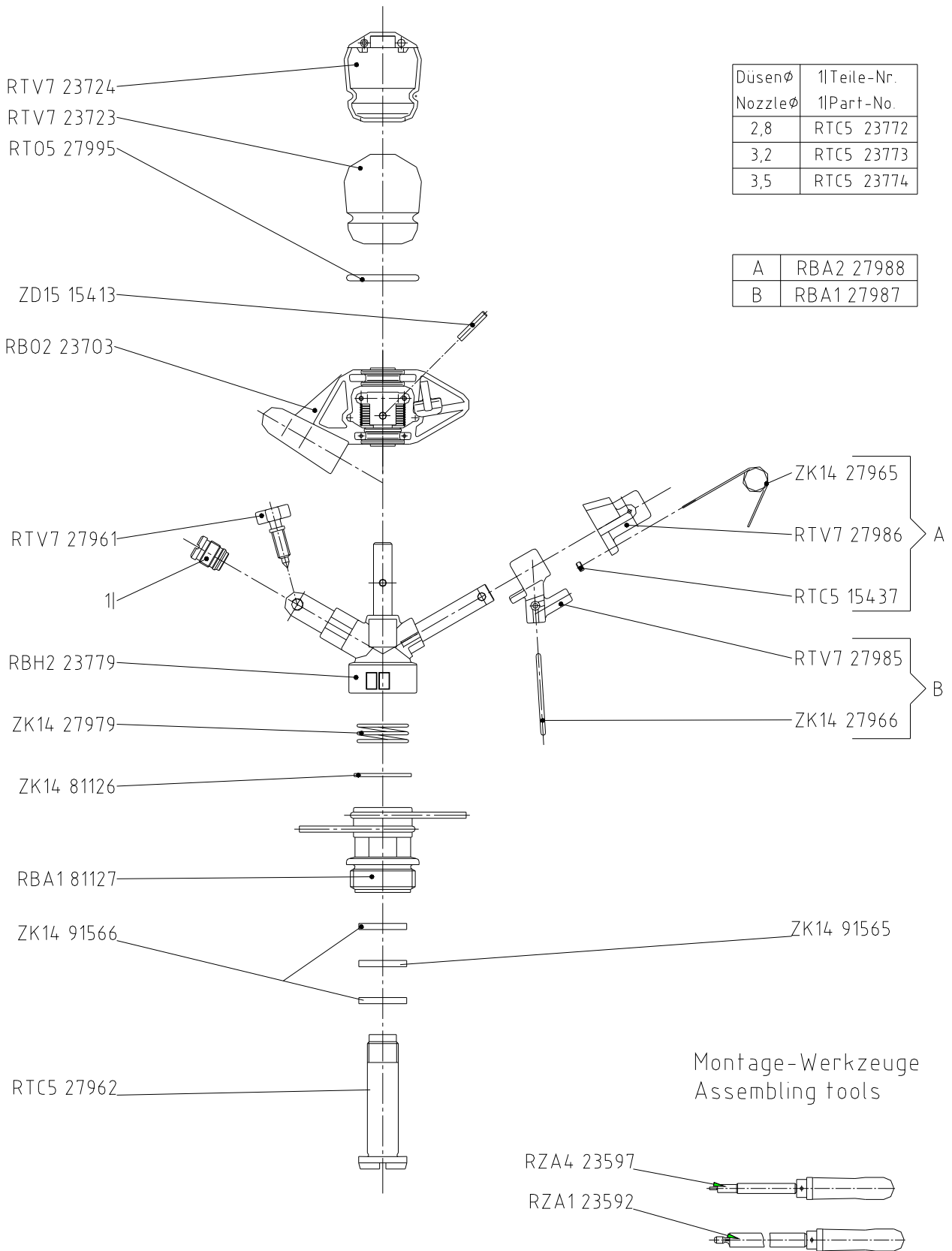

Stand: 24.05.2005
 ERF9 00161

ZA 7 / W / D

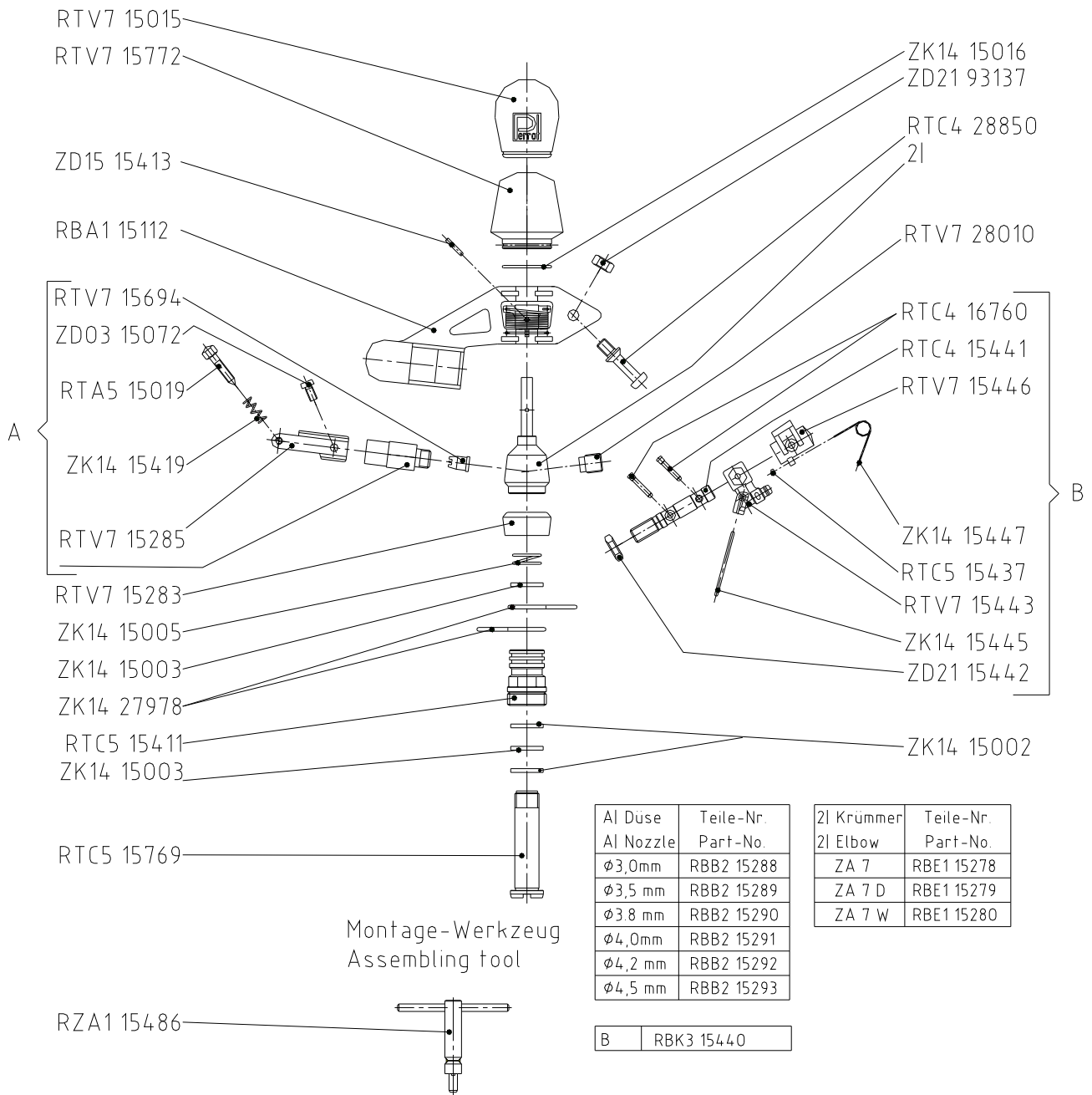

Stand: 26.10.2009
ERF9 00162

ZA 22-1 / D

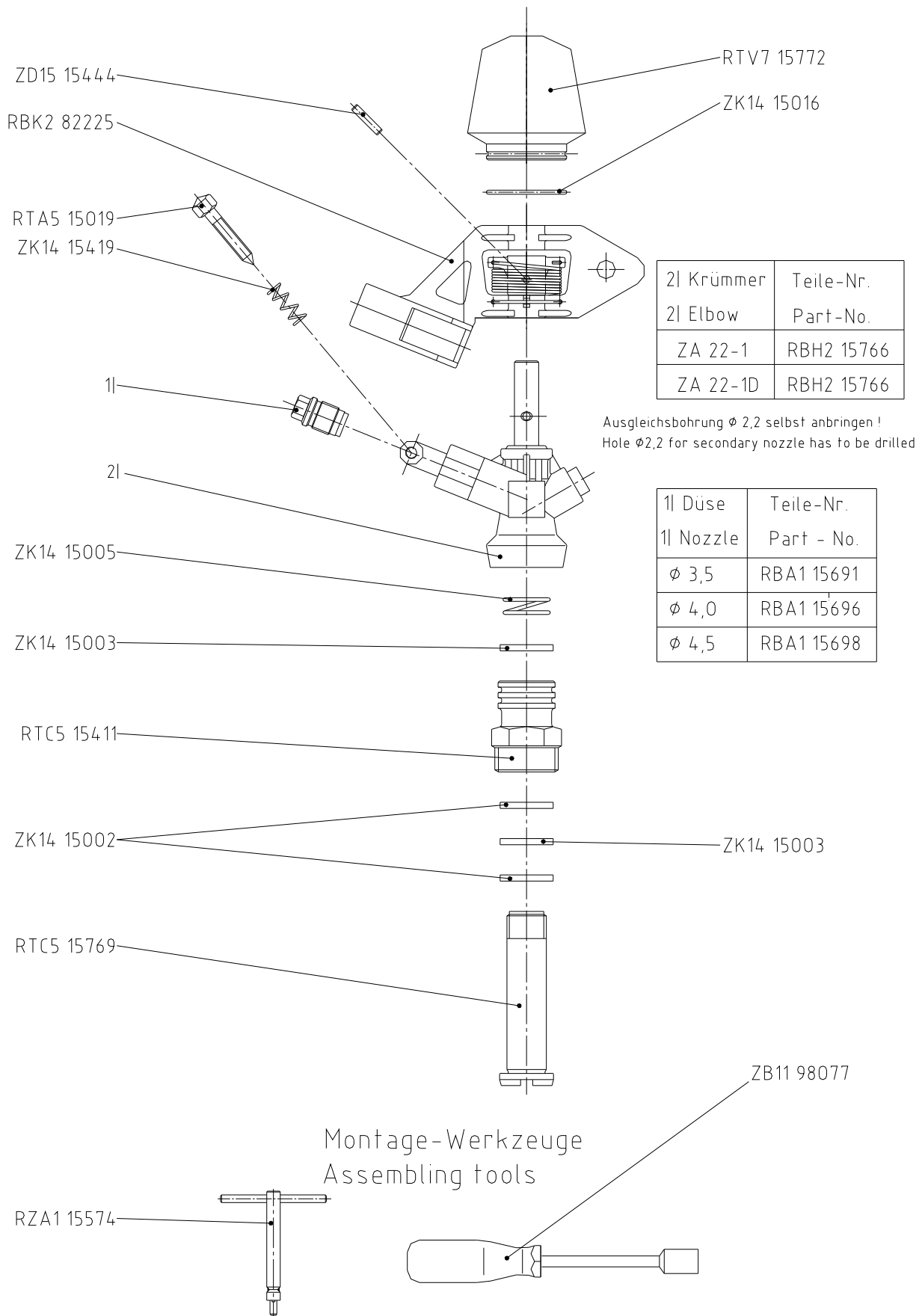

Stand: 28.10.2009
ERF9 00167

ZA 22-2 W

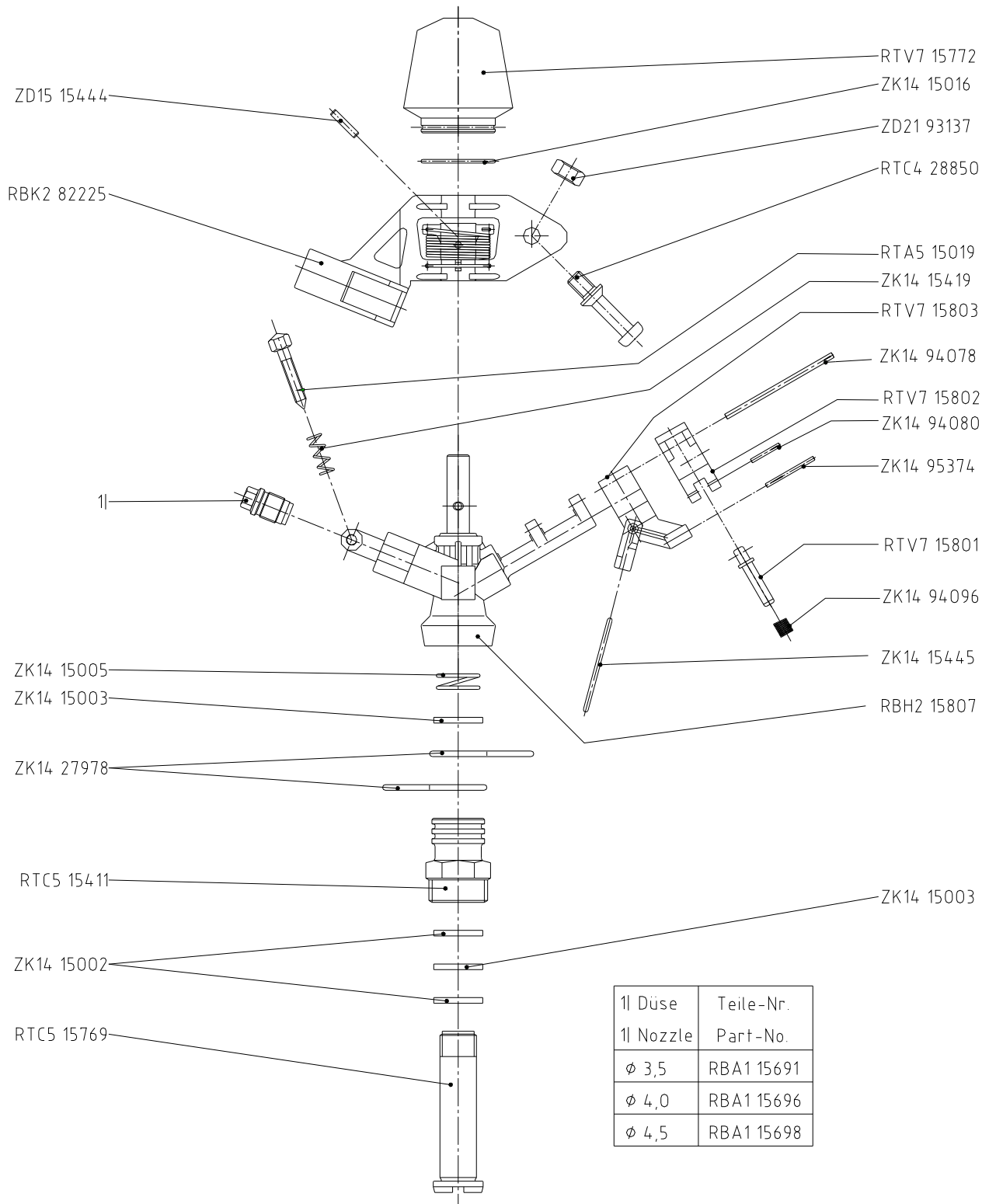

1l Düse	Teile-Nr.
1l Nozzle	Part-No.
∅ 3,5	RBA1 15691
∅ 4,0	RBA1 15696
∅ 4,5	RBA1 15698

Montage-Werkzeuge
Assembling tools

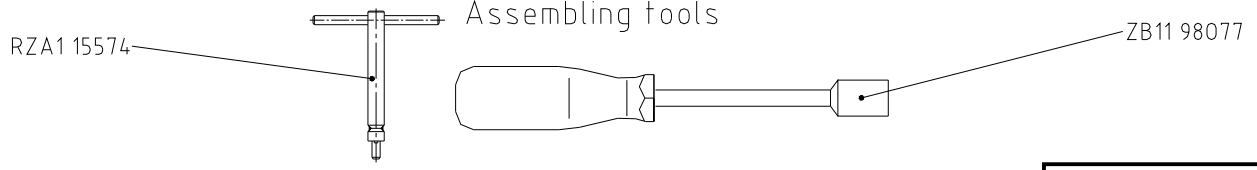

Stand: 28.10.2009
ERF9 00179

PR 14 / D

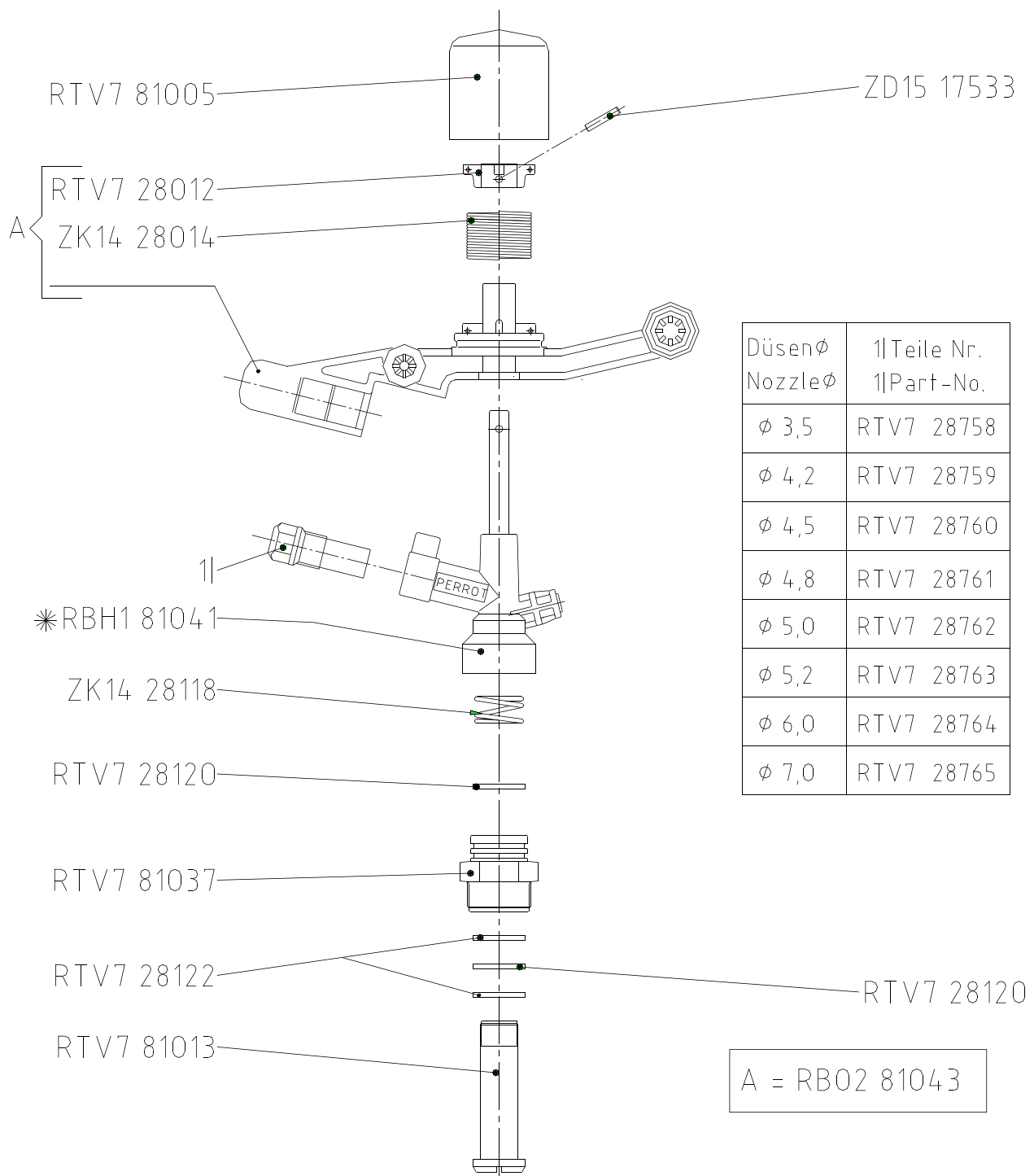

* bei D-Krümmen Ausgleichsbohrung ϕ 2,4 selbst anbringen
 Hole ϕ 2,4 for secondary nozzle has to be drilled

Stand: 39 / 05
 ERF9 00164

PR 24-1 D

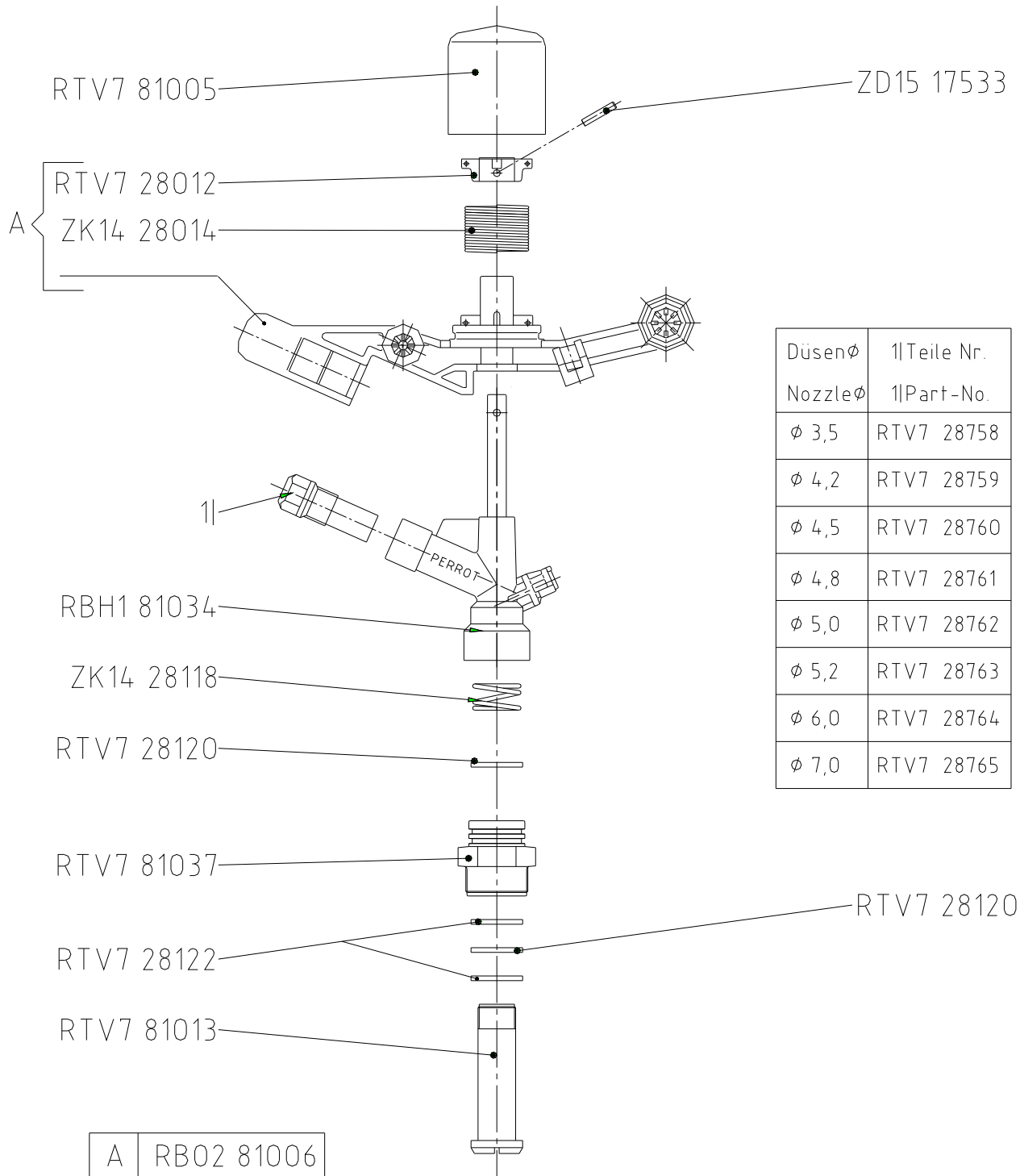

Stand: 39 / 05
ERF9 00165

PR 24-1 W

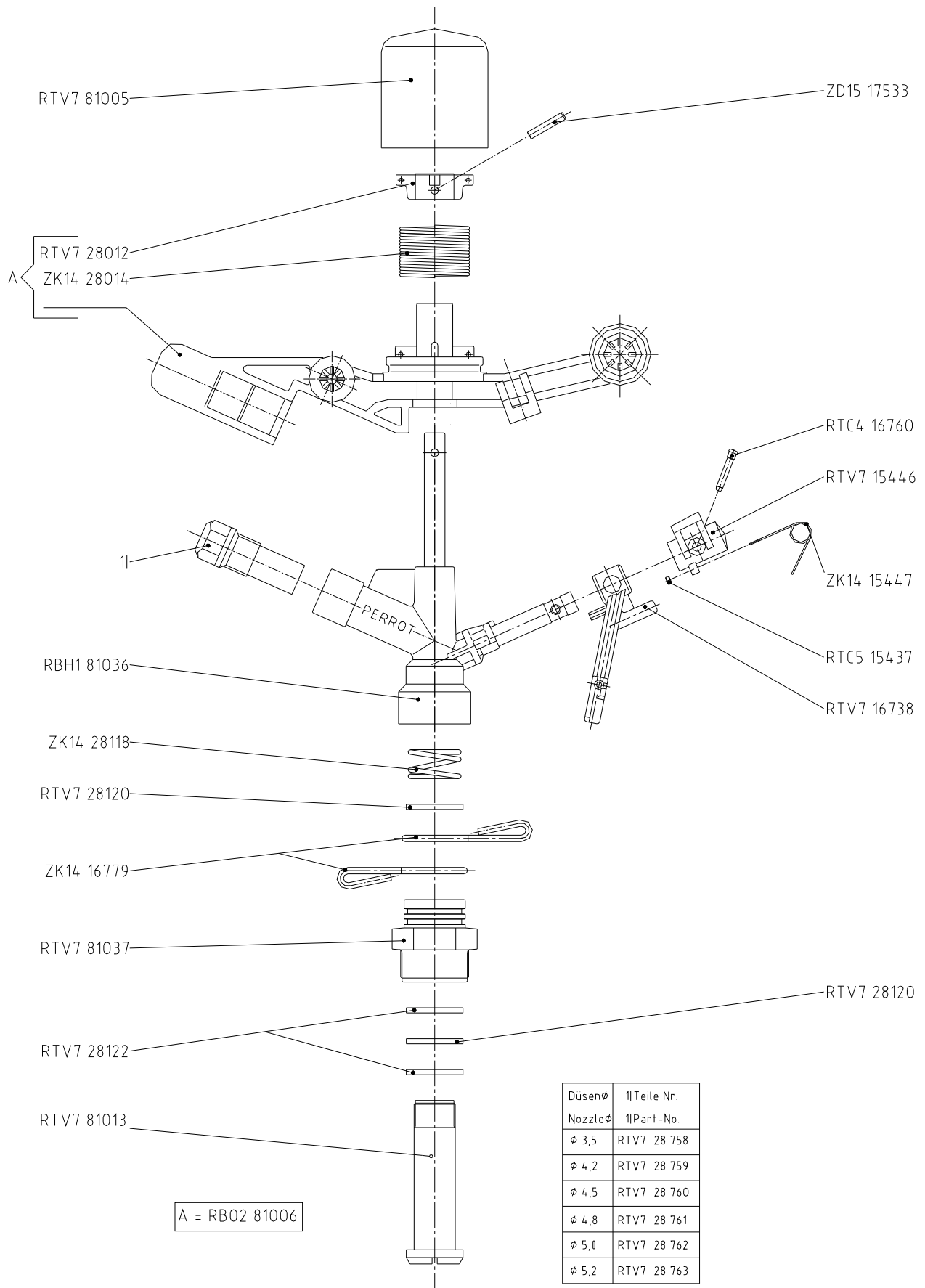

A = RB02 81006

Stand: 15.03.2005
ERF9 00186

ZS 30 mit Strahlstörer / with jet breaker

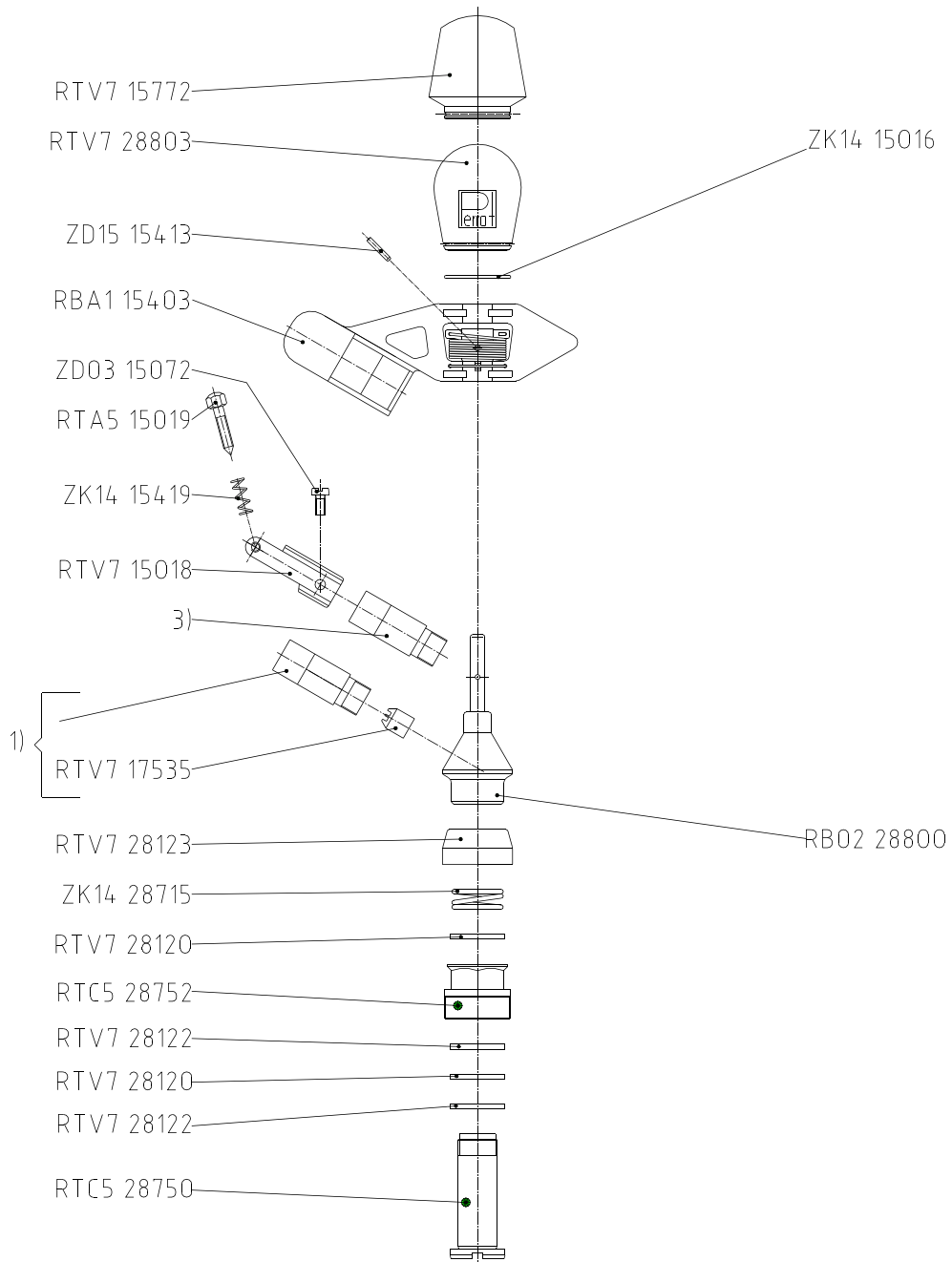

Montage-Werkzeug
Assembling tool

RZA1 28145

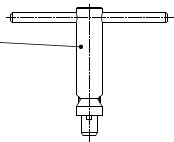

Düsen Nozzle	1) Teile-Nr. 1) Part-No.	3) Teile-Nr. 3) Part-No.
φ3,5	RBA1 28862	
φ4,0	RBA1 28843	
φ4,2	RBA1 28844	
φ4,5	RBA1 28845	RTL5 28855
φ4,8	RBA1 28846	RTL5 28856
φ5,2	RBA1 28847	RTL5 28857
φ6,0	RBA1 28848	

Stand: 22.10.2009
ERF9 00185

ZB 22-3 / W / D

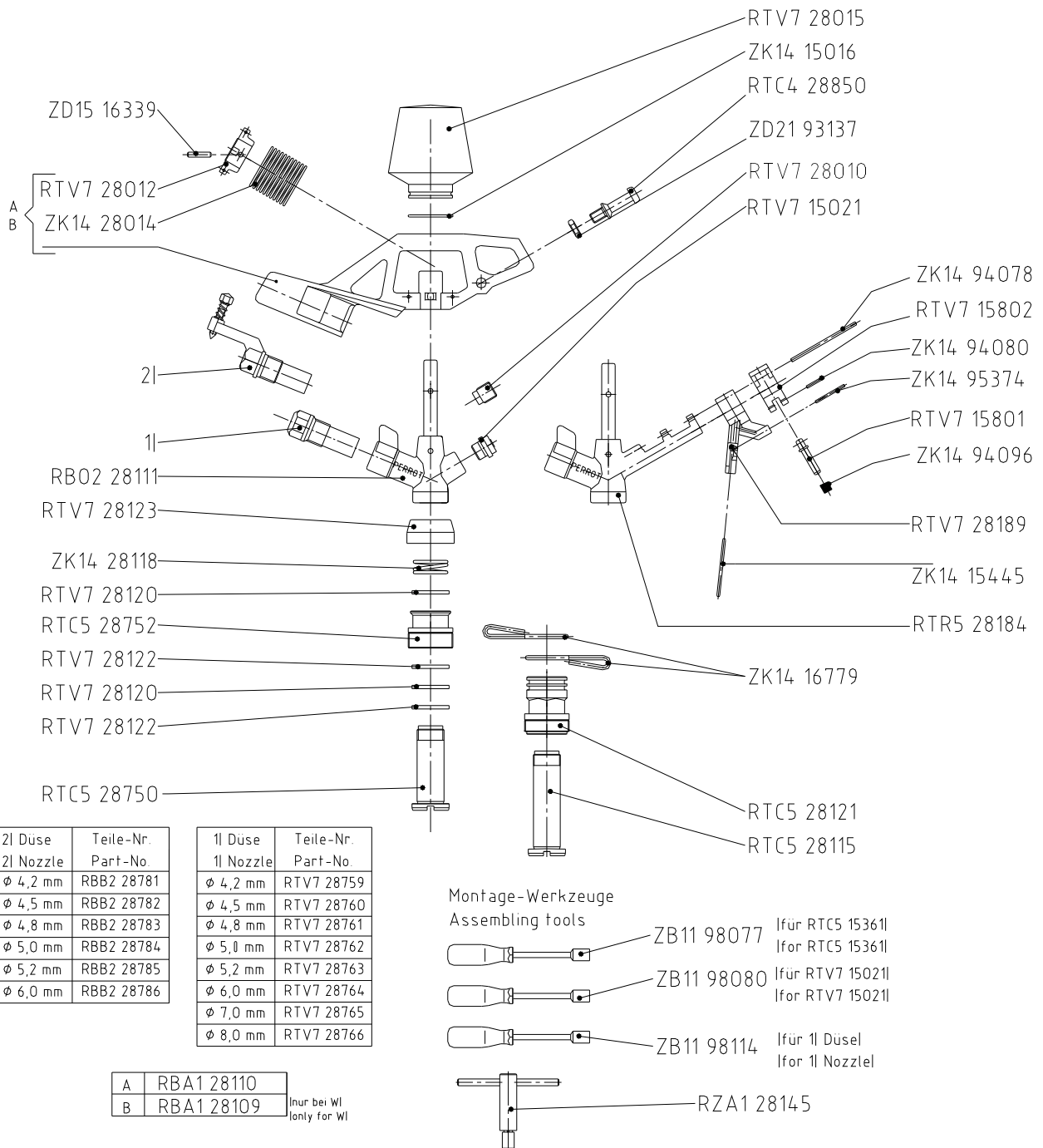

Stand: 30.06.2008
ERF9 00183

ZE 30 / D / W

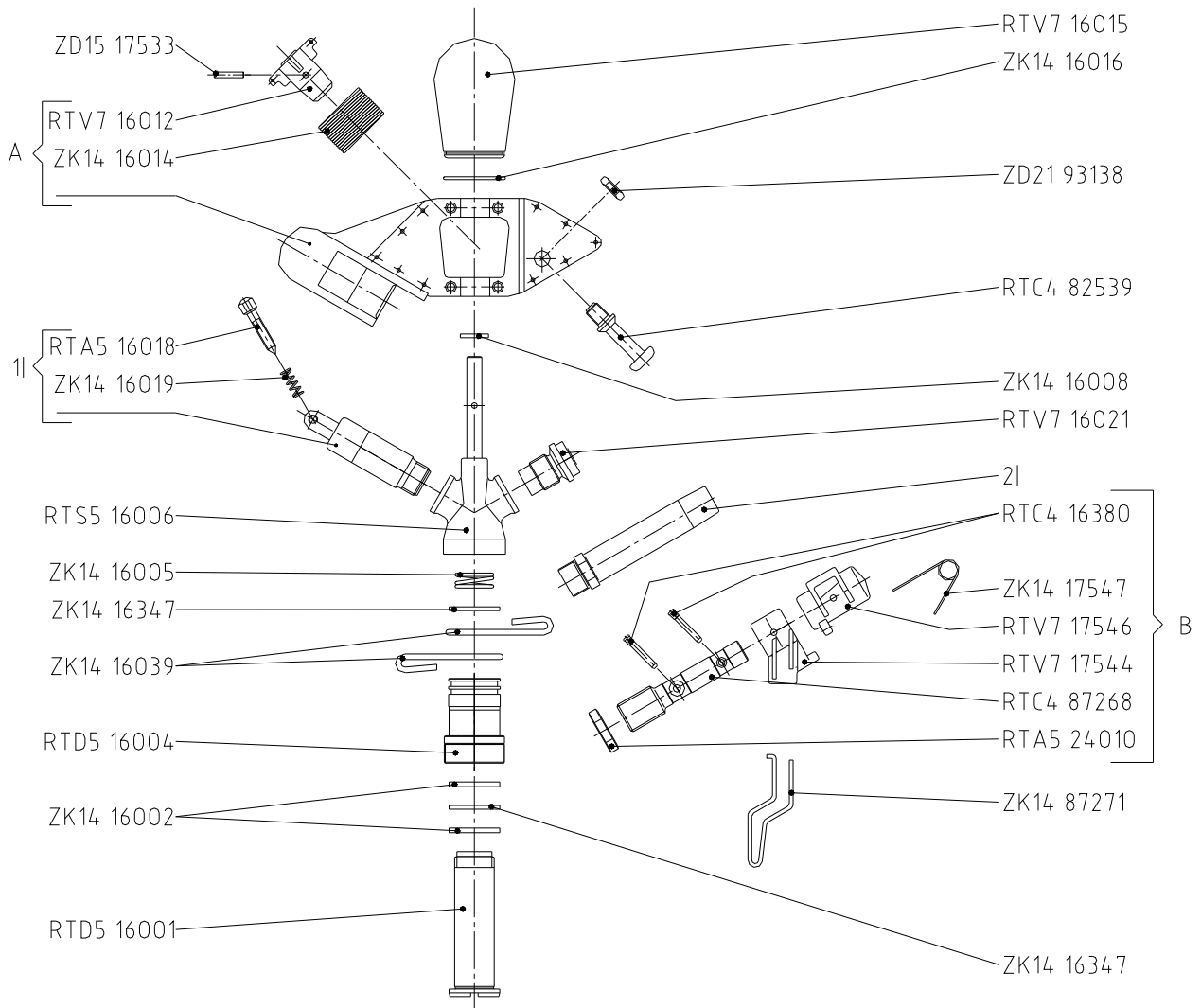

Montage-Werkzeug
Assembling tool

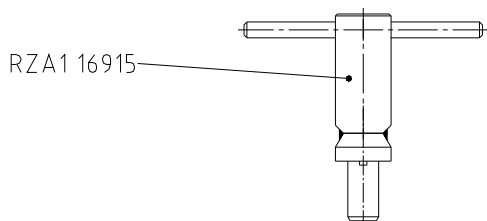

Düsen- ϕ Nozzle- ϕ	1l Teile-Nr. 1l Part-No.
4,5	RBB2 16358
5,0	RBB2 16360
6,0	RBB2 16362
7,0	RBB2 16363

Düsen- ϕ Nozzle- ϕ	2l Teile-Nr. 2l Part-No.
4,8	RTV7 16386
5,5	RTV7 16388
6,5	RTV7 16389
7,5	RTV7 16390
8,5	RTV7 16391

A	RBA1 16353
B	RBK3 87261

Stand: 32 / 02
ERF9 00168

ZK 30 / W

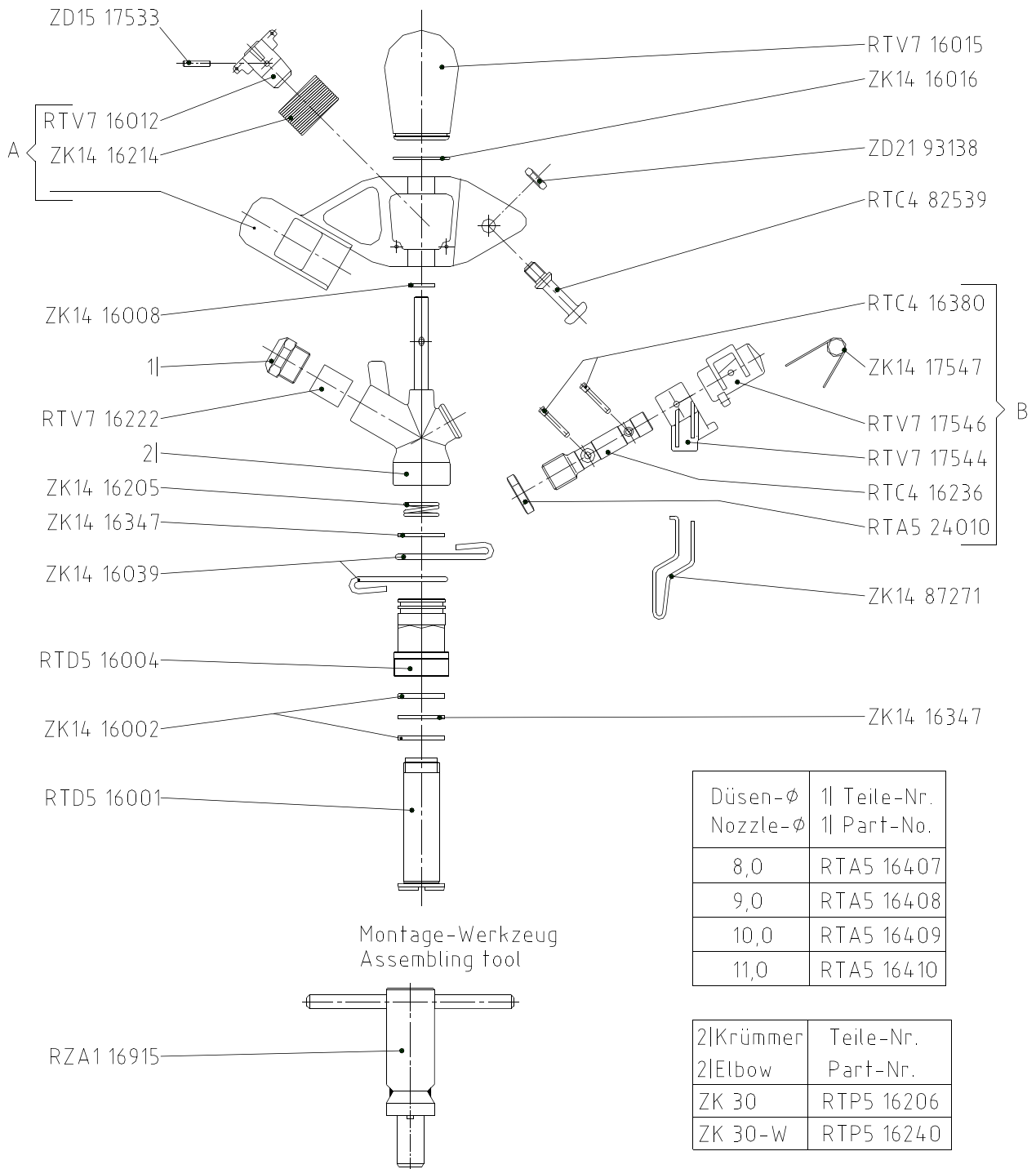

A	RBA1 16405
B	RBK3 16235

Stand: 20.09.2008
ERF9 00169

ZM 22 / W

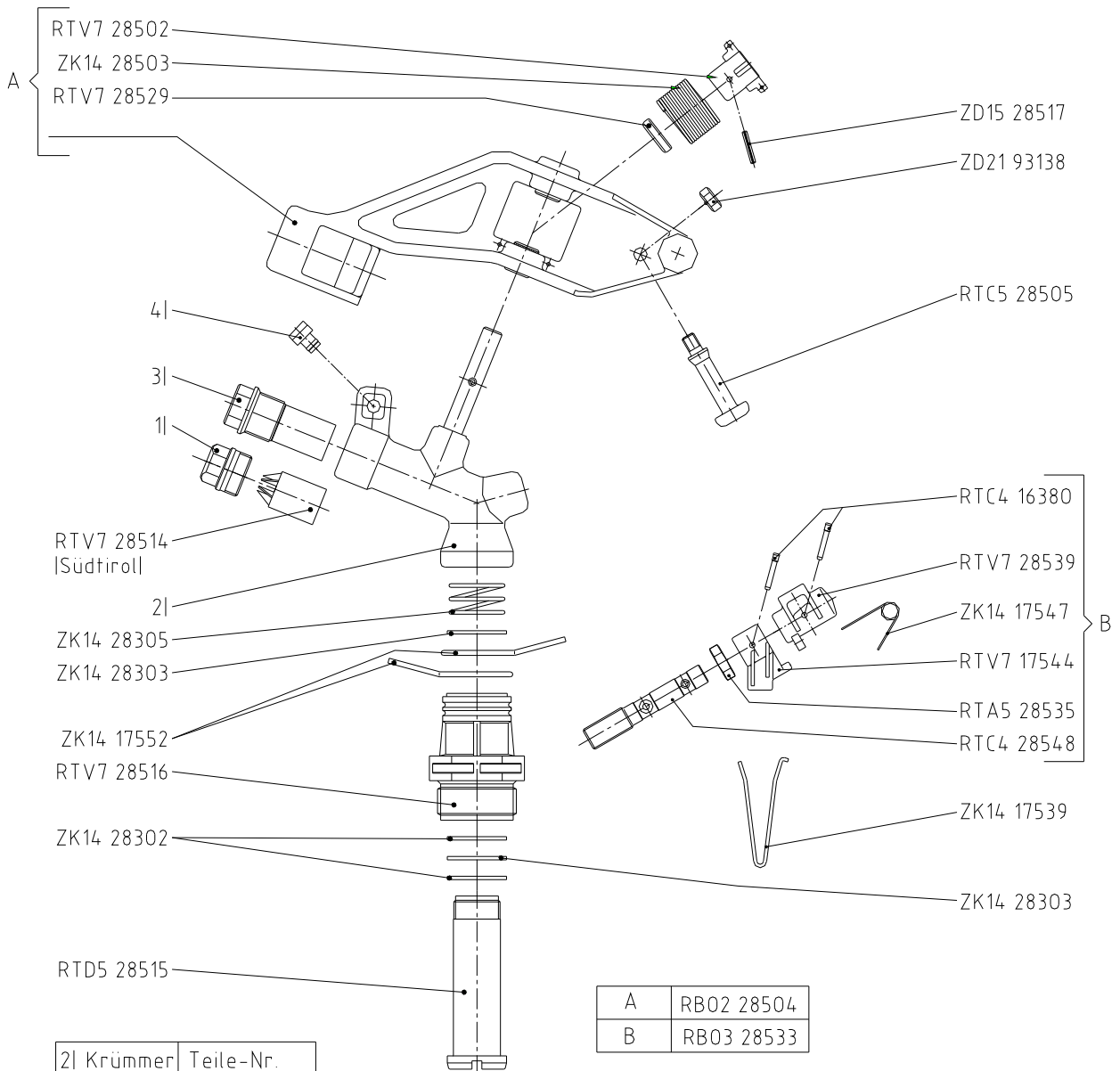

A	RB02 28504
B	RB03 28533

2 Krümmer 2 Elbow	Teile-Nr. Part-No.
ZM 22	RTR6 28509
ZM 22W	RTR6 28530

Montage-Werkzeug
Assembling tool

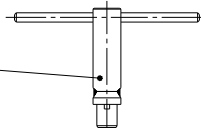

Düsen ϕ Nozzle ϕ	4
< ϕ 14	RTV7 28512 schwarz/black
> ϕ 14	RTV7 28513 rot/red

Teile Nr. Part-No.		
Düsen- ϕ Nozzle- ϕ	1 Messing 1 Brass	3 Kunststoff lab 08.99 3 Plastic since 08.99
ϕ 8	RTA5 28537	RTV7 17464
ϕ 10	RTA5 28518	RTV7 17466
ϕ 11	RTA5 28519	RTV7 17467
ϕ 12	RTA5 28520	RTV7 17468
ϕ 13	RTA5 28521	RTV7 17469
ϕ 14	RTA5 28522	RTV7 17470
ϕ 15	RTA5 28523	RTV7 17471
ϕ 16	RTA5 28524	RTV7 17472

Stand: 15.10.2007
ERF9 00170

ZN 23 + 45 -3 D / -3 W

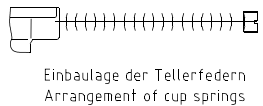
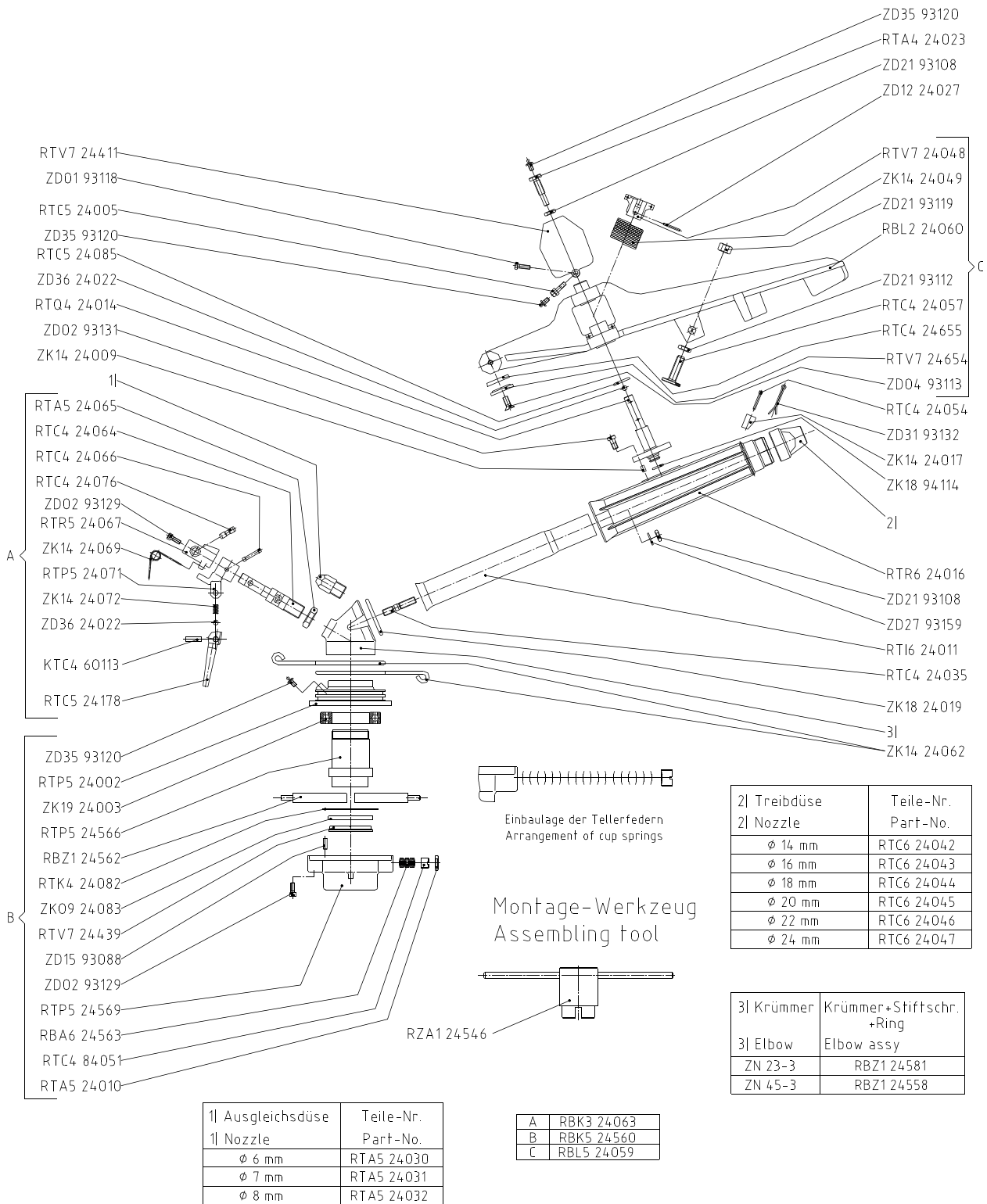

Montage-Werkzeug
Assembling tool

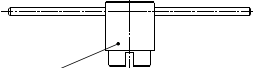

2I Treibdüse 2I Nozzle	Teile-Nr. Part-No.
φ 14 mm	RTC6 24042
φ 16 mm	RTC6 24043
φ 18 mm	RTC6 24044
φ 20 mm	RTC6 24045
φ 22 mm	RTC6 24046
φ 24 mm	RTC6 24047

3I Krümmer 3I Elbow	Krümmer+Stiftschr. +Ring Elbow assy
ZN 23-3	RBZ1 24581
ZN 45-3	RBZ1 24558

1I Ausgleichsdüse 1I Nozzle	Teile-Nr. Part-No.
φ 6 mm	RTA5 24030
φ 7 mm	RTA5 24031
φ 8 mm	RTA5 24032

A	RBK3 24063
B	RBK5 24560
C	RBL5 24059

Stand: 15.03.2005
ERF9 00171

ZN 23-3 W / VA + ZN 45-3 W / VA

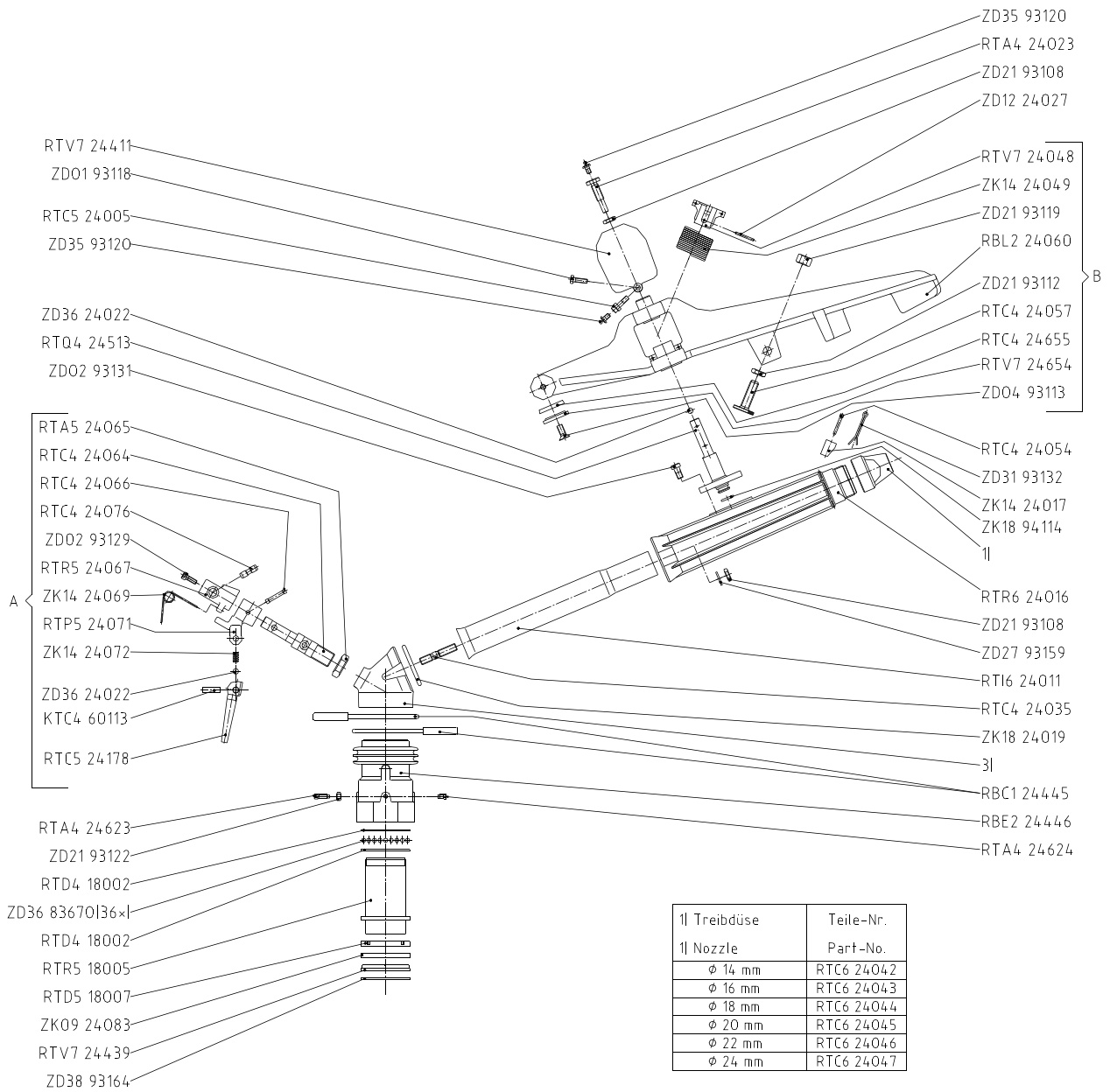

A	RBK3 24063
B	RBL5 24059

1 Treibdüse	Teile-Nr.
1 Nozzle	Part-No.
φ 14 mm	RTC6 24042
φ 16 mm	RTC6 24043
φ 18 mm	RTC6 24044
φ 20 mm	RTC6 24045
φ 22 mm	RTC6 24046
φ 24 mm	RTC6 24047

3 Krümmer	Krümmer+Stiftschr. +Ring
3 Elbow	Elbow assy
ZN 23-3	RBZ1 24581
ZN 45-3	RBZ1 24558

Stand: 15.03.2005
ERF9 00172

P2S

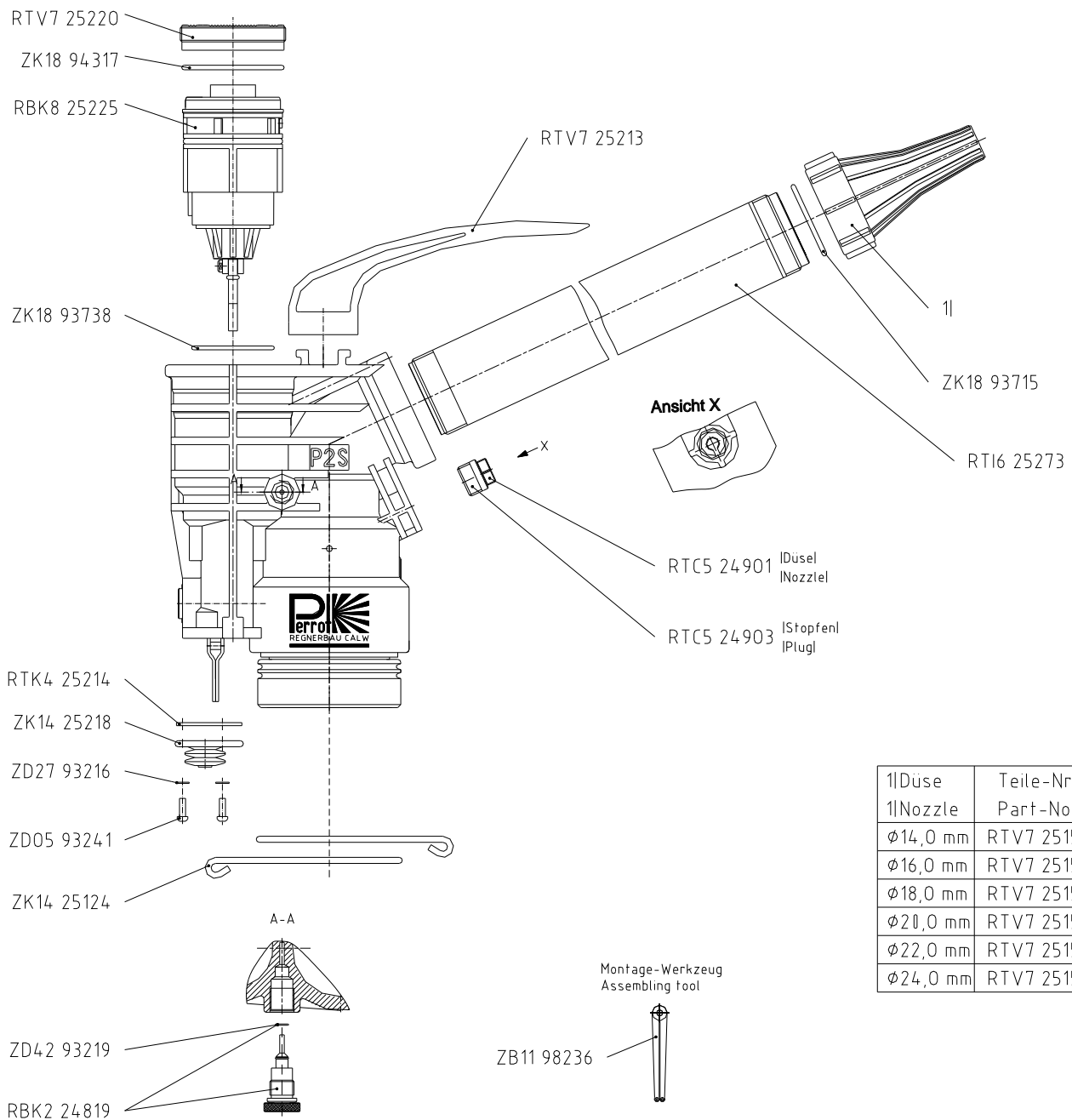

1 Düse 1 Nozzle	Teile-Nr. Part-No.
Ø14,0 mm	RTV7 25150
Ø16,0 mm	RTV7 25151
Ø18,0 mm	RTV7 25152
Ø20,0 mm	RTV7 25153
Ø22,0 mm	RTV7 25154
Ø24,0 mm	RTV7 25155

Stand: 11.11.2008
ERF9 00190

P2M

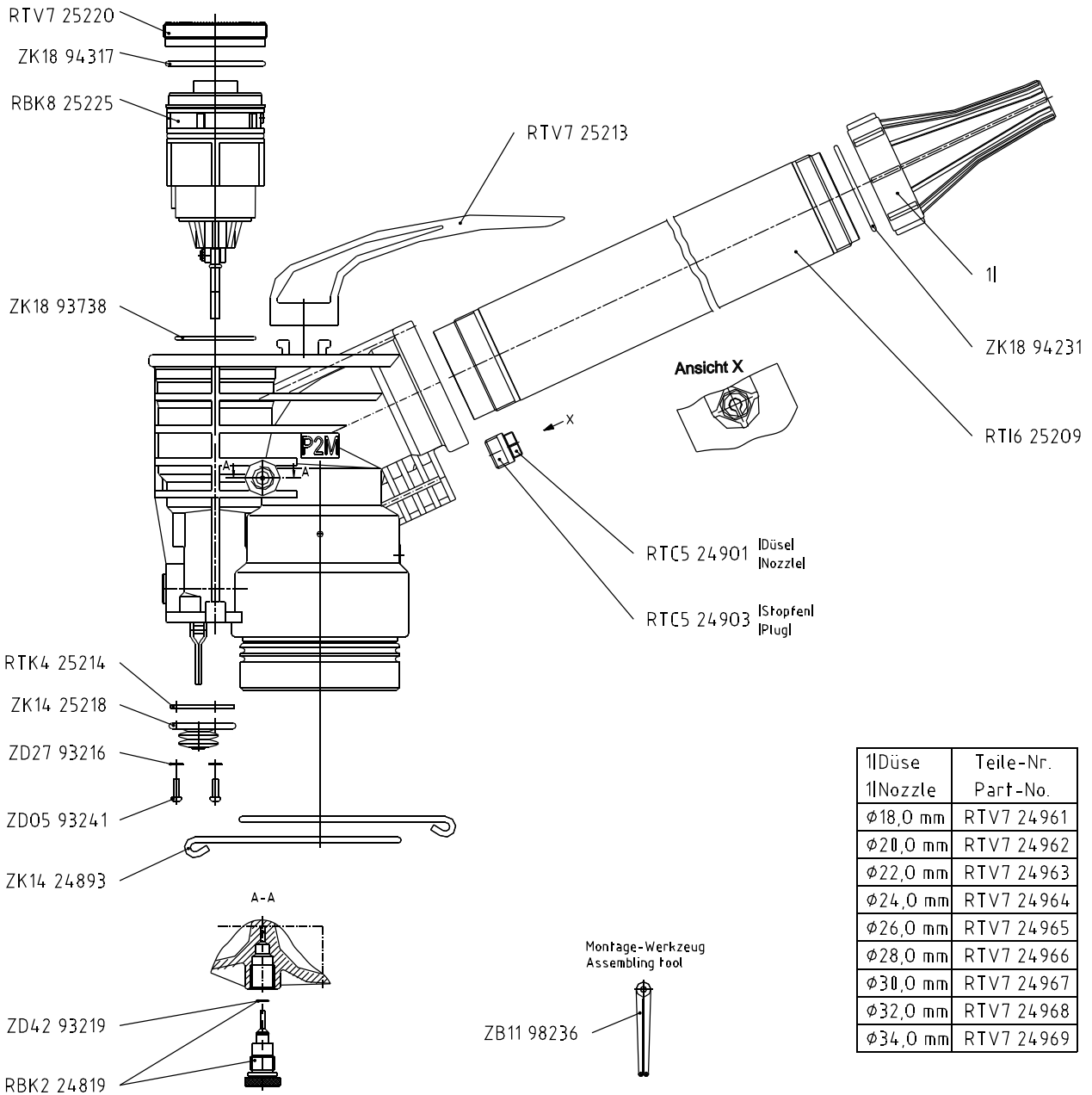

1 Düse 1 Nozzle	Teile-Nr. Part-No.
Ø18,0 mm	RTV7 24961
Ø20,0 mm	RTV7 24962
Ø22,0 mm	RTV7 24963
Ø24,0 mm	RTV7 24964
Ø26,0 mm	RTV7 24965
Ø28,0 mm	RTV7 24966
Ø30,0 mm	RTV7 24967
Ø32,0 mm	RTV7 24968
Ø34,0 mm	RTV7 24969

Stand: 18.01.2011
 ERF9 00189

TV 2000

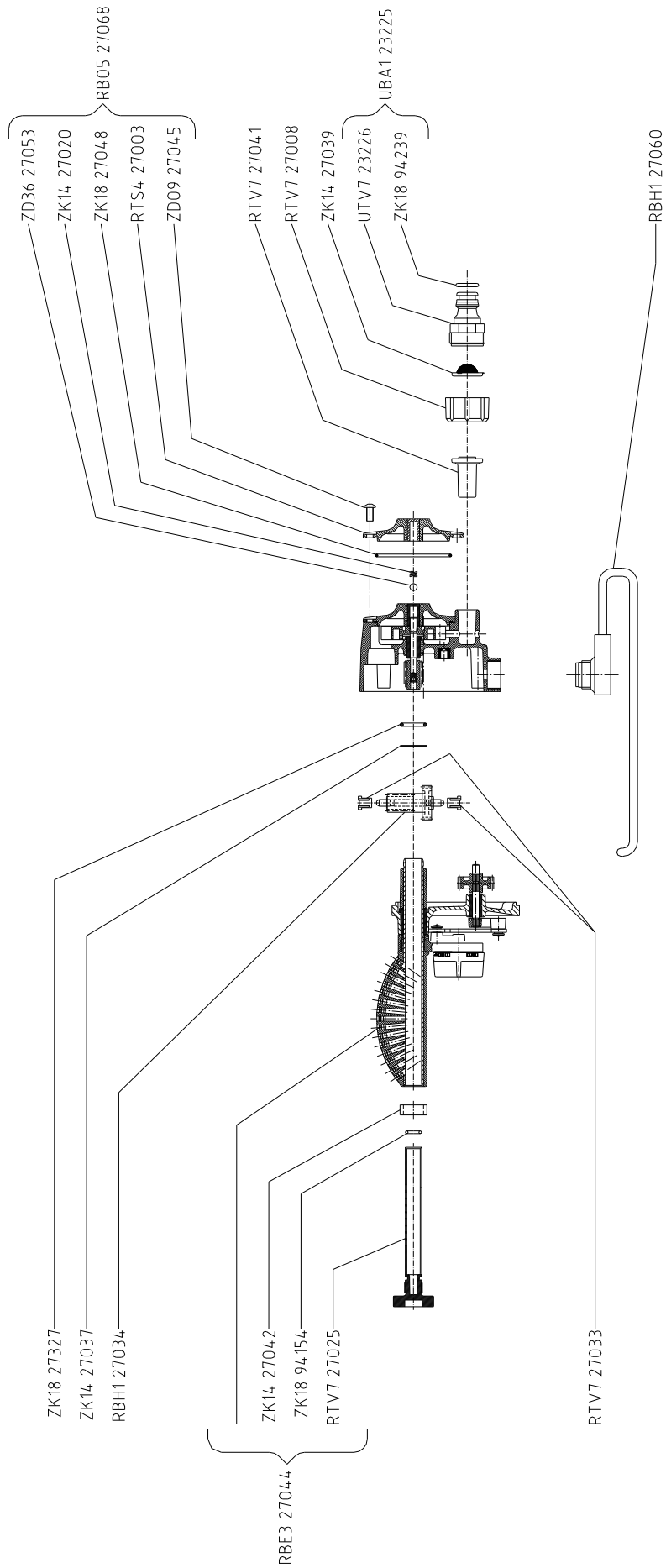

Stand: 27.09.2006
ERG9 00260

UNSER LIEFERPROGRAMM

Regner	für die Landwirtschaft, Forstwirtschaft, Gartenbau, Baumschulen und Umwelttechnik
Versenkregner	für Sport-, Tennis- und Golfanlagen, öffentliches Grün und Hausgärten
Gartenregner	Kreis-, Wende- und Viereckregner für den anspruchsvollen Garten
PE-Kupplungen	für PE-Erdleitungen
Kardan-Kupplung	für Rohre und Formteile aus Stahl verzinkt und Edelstahl (Material 1.4404)

OUR SALES PROGRAMM

Sprinklers	for agriculture, horticulture, forestry, tree nurseries and environment protection
Pop-up-sprinklers	for sportfields, tennis courts, golf courses, public greens and private gardens
Garden sprinklers	full and part circle sprinklers as well as quadrangle sprinklers for fastidious gardens
PE-couplings	for PE-pipes
Cardan couplings	for pipes and fittings made of galvanized steel and stainless steel (material 1.4404)